



Users' Manual for Transportation, Installation and Maintenance of Dry-type Air-core Reactor

Transmission Electrical
Energy Equipment

CONTENTS

1. Introduction	3
2. Safety	3
2.1 Overview.....	3
2.2 Electrical safety warning	3
2.3 Magnetic field.....	3
3. Technical Data, Dimension and Quality	3
4. Acceptance Inspection	3
4.1 Transportation	3
4.2 Packaging type.....	4
4.3 Packing marks.....	4
4.4 Check and approval of arrived goods.....	4
4.5 Uncasing.....	5
4.5.1 Wooden case.....	5
4.5.2 Plate.....	5
4.6 Visual inspection on the reactor after uncasing.....	5
4.7 Storage.....	6
4.7.1 Temporary storage.....	6
4.7.2 Long-term storage.....	6
5. Installation	6
5.1 Assembling of the reactor.....	6
5.2 Installation of the reactor.....	7
5.3 Checklist prior to power connection.....	12
6. Matters Worthy Attention During Equipment Operation	12
6.1 Vibration.....	12
6.2 External magnetic field.....	13
6.3 Contamination.....	13
6.4 Abnormal conditions.....	14
7. Inspection and Maintenance	14
7.1 Overview.....	14
7.2 Routine inspection or maintenance intervals.....	14
7.3 Routine inspection or maintenance items.....	15
7.4 Surface paint of the reactor.....	16
7.4.1 Material.....	16
7.4.2 Repair of surface paint.....	16
(a) Background.....	16
(b) Standard paint.....	16
(c) RTV paint.....	16
7.5 Cleaning of the reactor.....	16
7.6 Service life of surface paint.....	17
7.7 Repaint.....	18
7.7.1 Two-component paint.....	18
7.7.2 RTV Paint.....	18
Appendix I	21
Appendix II	22

General Rules

Make sure this manual is delivered to the final user along with the reactor!

1. Please follow the instructions in this manual and in other relative materials while using the reactor.

The user shall periodically carry out correct inspection and maintenance to ensure the normal operation of the reactor.

2. The user shall appoint an eligible operator with qualified certificate(s) to perform the installation, experiment, periodical inspection and maintenance of the reactor and keep record of the activities.
3. Please read this manual and other related materials before swinging, installing, debugging, running, maintaining or overhauling the reactor.

Make sure you have been familiar with all related information and safety precautions before using the reactor so as to have the ability of manipulating and operating it as required.

4. Please do not use any method which is not mentioned in the manual or violates stipulations in the manual to manipulate, operate or maintain the reactor or transform the reactor with parts or accessories provide by other manufacturers as these behaviors may result in the damage of the reactor or pose potential hazards to people.
5. If you have any question on the manual, please contact 'Transmission Electrical Energy Equipment directly.
6. In case of any malfunctions or other incidents regarding the reactor, such as short circuit and overload, the user shall have the duty of keeping a complete and unchanged record of running conditions of the abnormal operation, so as to clarify the responsibility and precisely work out precaution measures. Meanwhile, immediately contact relative department of our company and provide us with materials as follows:
 - a. Label content and details of the involving product, including name, Serial No., model and date of manufacture;
 - b. A description of the breakdown (try to give all the details, including abrupt conditions pre and post the breakdown).
7. The right of quality assurance revocation shall be reserved by our company in case the user fails to abide by our requirements of installation, testing, periodical inspection and maintenance for the reactor.

1. Introduction

The manual must be carefully and thoroughly read before the uncasing as it contains important information, such as how to safely carry the reactor, how to install and maintain it and etc.

The equipment provided is produced in accordance with relevant commercial contract and technology agreement. For plane layout of the reactor, see profile drawing of the reactor, and for scope of supply, see the packing list.

The producer shall take relative obligations for any damages or the failing of normal operation of the reactor due to quality deficiency within 12 months dating from the installation of the reactor and 18 months dating from the delivery date from factory on condition that the user abides by the rules of storage, installation and operation. For obligations borne by the producer, see relative stipulations in the agreement and contract.

Under normal installation, manipulation and maintenance of the product by users who strictly abide by stipulations of the producer, including those in this manual, in case of any damage or breakdown due to poor product quality, TEEE shall repair or change the product or its components for users for free within the warranty period stipulated in relative contract. For details, see stipulations in the commercial contract and technology agreement signed between the two parties.

2. Safety

2.1 Overview

As the equipment mentioned in this manual is for some special purposes, therefore its installation, operation and maintenance must be performed by people with professional qualification who know about relative risks. This manual is for reference for people with professional qualification only and shall not be used for the purpose of safety training of such equipment.

2.2 Electrical safety warning

When the reactor is under operation, its winding and all parts connected to the winding, such as terminal, holder and install fittings (see design details of in Chapter 3 in this manual) are electriferous. Therefore, contractor, customer or user of the reactor shall all have the responsibility of ensuring personal safety as per feasible power utilization safety rules and regulations during the installation, operation and maintenance of the equipment.

2.3 Magnetic field

When the reactor is electriferous, its magnetic field is not constrained but occupies the reactor's surrounding space. Although the intensity of magnetic field decreases when

the distance increases, still its influence on grounding conductors and metal objects in the surroundings of the reactor must be taken into consideration. The range to be considered depends on nominal parameters of the reactor. For detailed information, see Chapter 6.2 in this manual.

3. Technical Data, Dimension and Quality

See the attached profile drawing for relative technical parameters.

4. Acceptance Inspection

4.1 Transportation

All transportation of the equipment to and fro the installation site must be carried out in the condition of an intact packing and only suitable hoisting and transporting tools can be used. During the transportation, the product must be reliably fixed to the transportation tool and the vibration and collision during the hoisting and unloading must be avoided.

While hoisting the equipment, multipoint hoisting with special marks must be applied and make sure the points are under stress at the same time. During the hoisting, make sure the included angle between sling and the horizontal plane greater than 60 degrees.

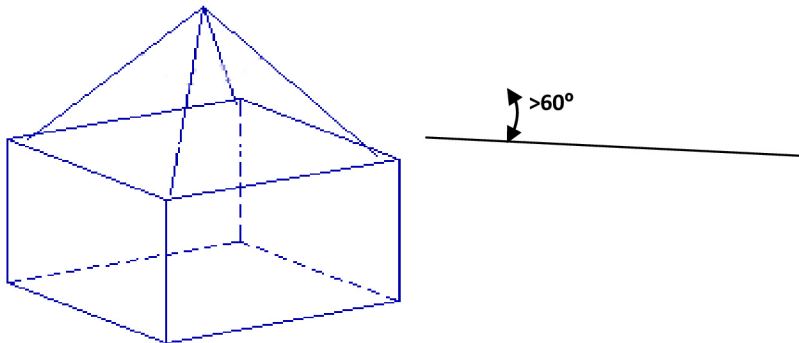

Attention:

Please be noted that if not all of the points are under stress at the same time, the reactor may be damaged due to unevenly stressing during the hoisting process!

4.2 Packaging type

In accordance with technical requirements in the contract, the reactor may be fastened to a plate and then encased in a wooden case or a heat shrinkable tube.

Attention:

For an equipment fastened to a plate, stacking up is prohibited.

For marine transported cases, however, they may be stacked up, but with a maximum stacking weight of 10 kN/m² and the cases to be packed should have a similar dimension.

4.3 Packing marks

Generally, there are several packing marks shown as follows:



"THIS SIDE UP"

Two UP arrows are used to indicate that while carrying the case, its direction must be kept upright.



FRAGILE

"Fragile"



This mark represents that while carrying the case, handling procedures for fragile objects must be followed.

4.4 Check and approval of arrived goods (items relating to the validity of warranty period)

Upon the arrival of the equipment, check the conformity of number of units according to the shipping paper and make a visual inspection on the status of packages.

In case of damaged packages, follow the procedures shown as below:

For evident damage to the packing, make a footnote on FCR and B/L or AWB immediately.

If the carrier of the goods is Transmission Electrical Energy Equipment, then the following procedures should be executed:

Immediately notify Transmission Electrical Energy Equipment of the exact damaged condition through fax, E-mail or telephone (For more details, please see the back cover of the manual);

All correspondence relative to the carrier or transportation insurance company must be copied and submitted to Transmission Electrical Energy Equipment.

The packaging can only be removed in the presence of the representative of the transportation insurance company to determine the damaged condition of reactor(s) and which party shall be responsible for the loss.

Submit a complete description of the damaged condition of reactor(s) to Transmission Electrical Energy Equipment so as to obtain the instruction for further action.

4.5 Uncasing

4.5.1 Wooden case

Try to make the uncasing site of reactor as near as possible to its installation site and perform the uncasing process on solid and horizontal ground. Follow the steps show below while performing the uncasing:

Before removing the cover of the wooden case, clean the top of the cover to avoid any fallen objects.

Dismantle the cover of the slatted crate or wooden case.

Dismantle the side board of the slatted crate or wooden case.

Remove the protective film.

Remove the bolt which fastens the reactor to the plate.

Take install fittings and small parts out of the crate or case and then check them with those shown in the packing list.

4.5.2 Plate

Remove the protective film;

Remove the bolt which fastens the reactor to the plate;

Take out install fittings and small parts from the plate and then check them with those shown in the packing list.

4.6 Visual inspection on the reactor after uncasing

After uncasing, carry out a visual inspection to check if there is any damage of the equipment according to the following steps:

Check the aluminium alloy posts both at the top and bottom of the reactor to see if there is any deformity or damage. If so, contact Transmission Electrical Energy Equipment instead of performing the installation.

Check the GRP belt on aluminium alloy post and the winding's incoming line terminal and leading-out terminal to see if there is any damage. If there is any breakage or severe crack on the winding terminal or bandage found, contact Transmission Electrical Energy Equipment instead of performing the installation.

Check if the surface coating of the reactor is damage. If the wire under the fiberglass encapsulation is exposed, contact Transmission Electrical Energy Equipment instead of performing the installation. If the coating (or paint) is just worn down, the installation can be proceeded with. Note: Only the specially purposed paint for the reactor can be used for its coating.

4.7 Storage

4.7.1 Temporary storage

If the reactor is not to be installed immediately after its arrival, then put it to a temporary depository instead of unpacking it (for apron conveying, do not remove its protective film). Under such circumstances, the product must be placed on horizontal ground which can bear its weight and make sure the environment is clean and there is no corrosive gas existed.

If the temporary depository is in the open air, then the storage time shall not exceed 6 months. The storage will only have an effect on the wooden packing material instead of the reactor.

4.7.2 Long-term storage

For long-term storage of the reactor, i.e. its spare parts, the wooden case must be well protected from direct rain or dampness to ensure the stableness and protectiveness of the packing materials. In this case, better store the equipment in an indoor or semi-indoor environment, where heating or air conditioning equipment is not required.

If it is not possible to store the reactor in an indoor or semi-indoor environment, then relative measures must be taken to make sure the bottom support of the plate is proper enough to make the reactor stay horizontal and water, mud or dust be kept out of the case. The outer of the case should be covered with oilcloth and periodical inspections should be performed to decrease the damage to the packing material caused by snow, rain and sunlight.

5. Installation

5.1 Assembling of the equipment

Installation of the reactor may be designed as a suspension type or a strut type.

Generally speaking, the reactor designed with an installation type of supporting insulator struts is not assembled when delivered. The hardware for assembly will be forwarded along with the reactor.

The assembly should follow the steps stipulated in the equipment installation instruction, which is one of the documents provided in each order.

The installation type, including single unit reactor, two overlapping or three overlapping reactor, may be distinguished from the equipment installation instruction.

It is suggested that before installing the reactor to equipment foundation, completely assemble the reactor, supporting insulator, prolonged base (if provided) and essential accessories or supporting lifting holder.

Some parts to be assembled are marked in the profile drawing provided along with the reactor or marked with label to correspond with assembly units in the installation instruction.

5.2 Installation of the reactor

Follow the procedures described below to carry out the installation or disassembly of the reactor.

Only the supplied lifting hook can be used for the hoisting of the reactor. Make sure the weight of the equipment evenly distributed to all hooks. For the hoisting of cable or rope chain, make sure the included angle between each cable or chain and another one less than 90 degrees.

Prevent the reactor from any vibration or collision during the process of hoisting or descending.

Hoist the reactor one by one and do not lift the reactor affiliated with a supporting insulator.

Do not tread on horizontal band and outgoing line terminal board.

Avoid pulling or knocking on the exposed wire between the aluminium alloy post and winding encapsulation.

The provided hardware for the reactor is made from non-magnetic stainless steel and any other hardware shall not be used.

If it is necessary to go up to the top of the reactor, make sure your shoes are clean and neat.

When working on top of the reactor or along with the border of the reactor, scattered objects should be taken out of your pockets to prevent them from falling into the cooling channel of the winding to cause breakdown of the reactor. If there is any fallen object, make sure it has been found and taken out before the reactor is started.

Fallen objects may also pose potential danger to work staff underneath the reactor and damage the umbrella skirt of supporting insulator.

If the power of the reactor is not connected during its installation, then one of its leading out terminals should be grounded until the system is power on. This may eliminate the possibility of accumulating scattered or inductive charges by the reactor under the influence of surrounding circuits or devices.

Before the power of the reactor is connected, make sure all magnetic influence distances mentioned in the profile drawing have been taken into consideration.

The correct position for fixing the foundation bolt has already been marked in the profile drawing.

Installation type of the reactor, such as single phase or three phase and etc., has already shown in the profile drawing. Carry out the installation as per relative instructions.

For assembly of the reactor, only provided hardware can be used.

Attention:

Please be noted that the torque of bolt must be tightened (see attached list of torque values in the manual).

For overlapped reactors, before screwing down the insulator of the reactor, use the matched intermediate gasket to fill the gap (1 mm above) to avoid from improper bending stress of the insulator.

As there are different reactor models, the cap of supporting insulator may be made of non-magnetic casting to avoid the reactor's magnetic field from generating an improper heating reaction. When exchanging an insulator which is damaged due to transportation, assembly or installation, pay special attention to the model of insulator (non-magnetic cap) and make sure it is the same with that of the damaged one.

List of Torque Values

Bolt Size (metric thread)	Torque
M5	5 Nm
M6	6 Nm
M8	15 Nm
M10	30 Nm
M12	50 Nm
M16	100 Nm
M20	150 Nm
M24	200 Nm

See the reactor's profile drawing to make the winding size and installation periphery accord with their dimensional requirements.

Place the installed reactor to a designated site on a cement board. Check the direction of terminal with that shown in the profile drawing.

Use suitable foundation fixing bolts to fasten the assembled reactor to the cement board. (Generally speaking, the foundation fixing bolts are not included in the provided hardware for the reactor).

Use self provided gasket to adjust the unevenness of dimensional tolerance between the assembly base and winding units.

Screw down the foundation fixing bolts as per suggested torque values.

5.2.1 Single phase reactor

See installation insulator, brace and etc. in the profile drawing. Fasten the bolt with your hand.

According to the hoisting instruction, place the reactor to the installation insulator or base. Check the terminal direction with that in the profile drawing, and then gently screw down the nut and do not tighten it up until the last lap.

Adjust the horizontal position between the installed reactor and the bracing structure.

Screw tight all bolts as per their recommended torque values (see List of Torque Values in the manual).

Connect the bus-bar or cable to the incoming line terminal or leading-out terminal.
For disassembly, reversely carry out the abovementioned procedures.

5.2.2 Overlapping of two reactors

First, align three electric reactors on the ground.

To determine the overlapping sequence, first check the S.N. on the nameplate on top of each reactor to get the information of their positions, such as top winding or bottom winding.

Assemble the bottom insulator and base according to the profile drawing of two overlapped reactors. Fasten the bolt with your hand. Based on the hoisting instruction, place the bottom reactor to the assembled bottom insulator or base, check the direction of its terminal with the one shown in the profile drawing, and then gently fasten the bolt.

Adjust the position between bottom reactor and fixing bolt and the horizontal position of the bracing structure.

Screw tight all bolts as per their recommended torque values (see List of Torque Values in the manual).

According to the profile drawing, install the interphase supporting insulator, supporting base and other parts to the top of the bottom reactor, and then screw tight the bolt with your hand.

According to the hoisting instruction, place the intermediate phase reactor to the interphase supporting insulator or supporting base. Check the terminal direction with that in the profile drawing.

Tighten all bolts as per recommended torque values (see List of Torque Values in this manual).

Connect the bus-bar clamp or cable to the incoming line terminal or bus-bar terminal.

5.2.3 Three phase overlapping reactor

First, align three electric reactors on the ground.

To determine the overlapping sequence, check S.N. on the nameplate on top of each reactor to get the information of their positions in the overlapping, namely, “top reactor”,

“middle reactor” and “bottom reactor”. If the nameplate is upturned, then the reactor should also be vertically upward placed.

Assemble the bottom insulator, base and other parts of the three phase overlapping electric reactor according to the profile drawing. Fasten the bolt with your hand.

Based on the hoisting instruction, place the bottom reactor to the assembled basic insulator or base, check the direction of its terminal with the one shown in the profile drawing, and then gently fasten the bolt.

Perform horizontal adjustment on the bottom reactor in accordance with positions of both the base fixing bolt and the bracing structure.

Screw tight all bolts as per their recommended torque values (see List of Torque Values in the manual).

According to the profile drawing, install the interphase supporting insulator and supporting base to the top of the bottom reactor, and then screw tight the bolt. Check the accessory profile drawing and nameplate of each intermediate phase reactor.

According to the hoisting instruction, place the intermediate phase reactor to the interphase supporting insulator and supporting base.

Check the terminal direction with that in the profile drawing.

Tighten all bolts as per recommended torque values (see List of Torque Values in this manual). Install the interphase insulator, base and other parts to the top of the intermediate reactor as guided by the profile drawing and then fasten the bolt.

Follow the hoisting instruction to place the top reactor onto the interphase insulator or base on top of the installed intermediate phase reactor.

Check the terminal’s direction with that shown in the profile drawing.

Fasten all bolts as per recommended torque values (see List of Torque Values in this manual).

Connect the bus-bar clamp to the incoming line terminal or leading-out terminal and bus-bar terminal.

For disassembly, reversely carry out the abovementioned procedures.

5.3 Checklist prior to power connection

Users are suggested to fill in the enclosed table (Appendix I) while checking the reactor.

Check items:	Signature /Date
1. Check if the reactor and its components are damaged during the transportation or installation (see Chapter 4).	×
2. Remove evidently marked transporting or hoisting parts and relative parts (if any)	×
3. Check tightened torques of all coupling bolts in on-site assembly, installation and electrical connection (see torque values in Chapter 5).	×
4. Check electric outlet of the reactor, make sure it is properly aligned and sags with enough space to avoid any improper static load on terminal.	×
5. Check the earthing connection to avoid potential closed circuit.	×
6. Check if there are some foreign objects in the airway, especially bolt, nut, washer or electric wire. Remove them before connecting the power.	×
7. Check if the surfaces of reactor and insulator are dirty. (If necessary, clean the reactor and insulator according to stipulations in Chapter 7 of this manual)	×
8. Check if the surface coating of reactor winding is damaged. If necessary, mend the damaged surface (see Chapter 7 in this manual).	×
9. Before the power is connected, get rid of all items with no relation to the operation of reactor, such as tools, bolts, metal parts, ladder and felt.	×
10. Check all equipment, fence, building and inlet cable on the surface of winding or near the winding to make sure their metal sheaths have proper yoke distances.	×

6. Matters Worthy Attention During Equipment Operation

6.1 Vibration

When a magnetic field passes through the winding of the reactor, electromagnetic force is generated. The forces act on the electriferous leading wire and the aluminium alloy post with electrical load. All the forces are in direct proportion to the square of the electric current. Under the condition of single frequency AC, the electromagnetic force

oscillates with a frequency one times higher than that of electricity. The oscillating force on the winding triggers the vibration of the reactor both in axial and radial directions. The vibration of the winding will be further transmitted to its mechanical joints. The degree of vibration depends on the capacity of the reactor. Large capacity shunt reactors and smoothing reactors have evident vibrations, while other types of reactors, such as current limiting reactor, damping reactor and filter reactor are basically free from vibration.

If the bolt is not tightened, the vibration will cause loosening of the bolt itself, as well as the reactor and adjacent assembly units of its supporting structure.

In addition, noises may be generated and emitted by the vibration of the surface of the reactor. Essentially, the noise is a pitch which varies with the load current of the reactor. However, if there is an evident vibration in the typical pitch, such as quacking, it means some parts may be loosened. Supporting braces of large reactors may subside a bit during their operation, which may result in tiny cracking of some parts of the reactor, especially between the aluminium alloy post and end rings, the winding's outgoing and inletting wire and the ending of the winding. During routine maintenance, you may find such tiny cracks, which do not indicate the abnormality of the reactor's performance. However, if you have some questions on evident crack(s), please contact Transmission Electrical Energy Equipment for help.

6.2 External magnetic field

The magnetic field generated by the reactor may trigger an eddy current in its adjacent metal parts, concrete bars in the cement foundation or the earthing system. Some heat or electrodynamic force may be generated as per the size and shape of these metal pieces.

Signal lines for system control, protection, voice or data transmission and electronic devices shall to some extent shield or keep away from the reactor's area.

For the influence of magnetic field on human health, limitations of human exposure to magnetic field stipulated in laws and regulations of local governments must be considered. There are some countries and international organizations that have proposed detailed rules and regulations regarding the limiting values of magnetic field exposure.

Based on the rules and regulations, we suggest the limiting value of magnetic field exposure in a public place is 0.1mT.

Compared with other types of products, dry-type air-core reactor generates the max. magnetic field. Therefore, the axial distance is suggested setting at 3 to 4 times the size of the winding's diameter. For more information of the surrounding magnetic field, see the profile drawing.

6.3 Contamination

Some reactors are installed in regions with highly urban industrial pollutions or marine pollutions.

Under such rugged surroundings, the surface of reactor may have the trace of tracking when impacted by an alternating electric field. If this situation has been aware of before the reactor is produced and the reactor should have a large voltage drop, then anti-tracking coating should be used on the surface of the reactor. The coating is a single component low-temperature setting silicone rubber elastomer, which features special hydrophobicity and the ability of preventing the formation of water film on the surface of the reactor. An antifouling shield may also be used on top or in periphery of the reactor.

6.4 Abnormal conditions

For prudent reasons, it is suggested performing periodical inspections on the product during its operation, which may be carried out at a safety distance to the product.

For reactors with a large capacity, i.e. shunt reactor and smoothing reactor, special attention should be paid to their sounds to find if there is any abnormal tone, i.e. quacking means the loosening of some parts. Under this circumstance, perform a check on the reactor and all fixing parts when the power is cut off. If the noise source cannot be found, notify Transmission Electrical Energy Equipment.

Under a rugged environment, the surface of the reactor should be checked aperiodically for black trace of tracking. If the trace is detected, perform a careful check on the reactor when the power is cut off. Take photo(s) of the trace and send it (them) to Transmission Electrical Energy Equipment.

7. Inspection and Maintenance

7.1 Overview

To ensure the long-term and reliable operation of the reactor, periodical inspection and maintenance of the reactor shall be carried out.

The period of inspection and maintenance depends on the reactor's type, capacity, operating load and on site environmental conditions.

For large scale reactors, especially shunt reactor and high voltage direct current smoothing reactor, a routine inspection must be performed annually. For other reactors, such as current limiting reactor, filter reactor and damping reactor, the inspection may be performed every five years in condition that the equipment is installed under a normal environment. For those installed under an unfavorable environment, the reactors are suggested having the inspection every year; for very bad environment, it is recommend that the inspection should be carried out frequently.

In case of any severe running conditions or environmental conditions borne by the reactor, an extra check on the reactor is suggested.

If the reactor suffers a large short circuit current or large transient overvoltage, then an inspection should be performed on the equipment.

If the reactor is installed in a rugged environment, i.e. the reactor suffers an accidental pollution, then the equipment should be checked for black tracking.

If the reactor undergoes a serious earthquake, its structural support should also be checked.

Any factor of the electric power system or the environment that may cause the reactor to bear the technical parameters exceeding the stipulated values should be marked and provided to Transmission Electrical Energy Equipment for evaluation (Please refer to the cover).

When carrying out an inspection on the reactor, the power should be cut off and make sure all equipment have been safely grounded. If necessary, use ladder to check the top of the reactor.

7.2 Routine inspection or maintenance intervals

Maintenance interval as 1 year (Min. interval): The suggested maintenance interval is 1 year for any reactor that is installed in an unfavorable environment.

The interval also applies to shunt reactors and high voltage direct current smoothing reactor (regardless of field environment).

Maintenance interval as 5 years: For current limiting reactors, neutral grounding reactor, filter reactor, damping reactor, electric-arc furnace purposed series reactor and

etc., the maintenance interval is suggested as 5 years (this applies to reactors installed in general environment conditions).

7.3 Routine inspection or maintenance items (1 year or 5 years interval)

Users are suggested to fill in Appendix II while carrying out the routine inspection

Signature/Date

1. Normally, carry out visual inspection on the product to see if it is complete.	×
2. Check if the wire between the reactor's winding encapsulation and aluminium alloy post is damaged or broken.	×
3. Check if the GRP belt on the aluminium alloy post is loosened.	×
4. Check if there is any abnormality on top end and bottom end of the winding, such as carbonization and trace of electric arc.	×
5. Check the top end of winding and airway to see if there is any foreign object, especially bird net. If so, eliminate the sundries.	×
6. Check both the inner surface and outer surface of the reactor winding to see if there is any trace of electric discharge.	×
7. Check if the bolt of the supporting structure has been tightened.	×
8. Check the status of the grounding cable, such as tightening status of bolt, any sign of corrosion and etc.	×
9. Check if the surfaces of the reactor and insulator are contaminated. If necessary, clean the reactor and insulator referring to stipulations in Chapter 7.	×
10. Check the protective paint of the reactor. For local deficiency or peeling off of paint, repair the paint (see Chapter 7). Under normal environment conditions, it is suggested the reactor should be repainted after running for 10 to 15 years.	×
11. Remove all irrelevant parts before the power is connected, such as tools, bolt, other metal parts, ladder, oil cloth and etc.	×
12. If the acoustic shield is provided along with the winding, check if the sound absorption sponge within the shield is loosened or has slid away from its initial installed position.	×

7.4 Surface paint of the reactor

7.4.1 Material

There are two types of surface paints used on TEEE's reactors. They namely consist of: two-component paint and RTV paint (which is necessary/ required).

The storage life of both unsealed two-component paint and RTV paint is around one year.

7.4.2 Repair of surface paint

(a). Background

Despite that the repair of surface paint is not an urgent issue, it still requires the consideration of suitable time, condition and method.

Attention:

The top finishing shall only be performed under dry conditions with the environment temperature above 10 °C.

(b). Standard paint

Gently rub off any deficiency found on the surface with a 150-grit abrasive paper.

Clear the clingage with naphtha or other suitable lacquer diluents.

Make the two-component paint with provided blending ratio for the mixings.

Paint the damaged place with brush, roller or spray gun.

(c). RTV paint

Remove the clingage with naphtha or other suitable lacquer diluents.

Paint the damaged place with roller or air-free spray gun (generally speaking, brush shall be not used in the painting).

7.5 Cleaning of the reactor

Normally, there is no need to clean the reactor if it is installed under normal environment conditions. For special conditions which require the cleaning of insulator, the cleaning of the reactor is also recommended and its cleaning interval shall remain the same with that of the insulator.

For an reactor which is installed in a place that may be severely contaminated at times, such as salt deposition caused by salt fog or severe industrial pollution caused by a processing accident, the cleaning must be performed as soon as the incident is over.

The cleaning only involves the use of clean water. For poor cleaning effect, non corrosive detergent may be added for the cleaning. In the end, make sure the reactor is rinsed again by clean water.

Attention:

For reactors using RTV paint, detergents are strictly prohibited in their cleaning as the hydrophobicity of the equipment would be reduced for a certain time.

TEEE suggests the use of a spray gun with an expandable nozzle. If necessary, use tissue paper or soft nylon brush to increase the cleaning effect.

The cooling air way between the sealing layers should also be cleaned with water by a spray gun.

Attention:

Make sure the underground water which may possibly be used in the cleaning of the reactor must be absolutely clean.

Before connected to power, the reactor must be completely dried out. The Min. time of drying depends on the environment temperatures. Normally, 12 hours would be OK.

7.6 Service life of surface paint

The service life of both two-component paint and RTV paint adopted by TEEE has a close relation to on sited conditions, such as Max. and Min. temperatures, duration under the operating temperature, whether exposed under UV and the exposure intensity, extreme climate, pollution (amount and types) and etc.

Based on strict standards, including service life, the two paints have passed quality certification and may be selected and used. According to our experiences of installation, the service life of standard paints is between 10 to 20 years and that of RTV paint is over 10 years.

However, the real service life depends on on-site operating conditions. Therefore, it is suggested that periodical assessment on the conditions of the two-component paint and RTV paint be carried out based on their signs of degradation. If any sign of degradation is found, notice Transmission Electrical Energy Equipment to carry out an evaluation. If it

is considered as necessary, on site repainting may be carried out. Only materials recognized by TEEE can be used. TEEE may provide materials and instructions for use, and also send skilled personnel to perform the repainting.

7.7 Repaint (items relating to the validity of warranty period)

7.7.1 Two-component paint

Detailed repaint instructions and materials may be provided by TEEE. The surface preparation is very important, as well as climate conditions. The repaint may be carried out by brush, roller or spray gun.

7.7.2 RTV paint

Basic repaint procedures are as follows:

1. If it is impossible to remove all loosened RTV paint or RTV paint sheets, a new layer of RTV paint may be coated on the previous paint surface.
2. Remove loosened RTV paint or RTV paint sheets. For the surface preparation for the repaint, the easiest way is to flush with high pressure water.
3. The winding surface should be kept dry but not fully dry as water is one of the components of curing the RTV paint. When touching the paint surface, the feeling of damp should be detected and no obvious trace of water left by surface preparation cleaning should be found.
4. The repaint of RTV paint is allowed. Follow stipulated procedures to direct cover the previous RTV paint.
5. If necessary, completely remove the precious RTV paint. The high pressure sand blasting system is recommended.

Appendix I

Checklist prior to power connection

Check items:

Signature Date

1. Check if the reactor and its components are damaged during the transportation or installation (see Chapter 4).		
2. Remove evident marked transporting or hoisting parts and relative parts (if any)		
3. Check tightened torques of all coupling bolts in on site assembly, installation and electrical connection (see torque values in Chapter 5).		
4. Check electric outlet of the reactor, make sure it is properly aligned and sags with enough space to avoid any improper static load on terminal.		
5. Check the earthing connection to avoid potential closed circuit.		
6. Check if there are some foreign objects in the airway, especially bolt, nut, washer or electric wire. Remove them before connecting the power.		
7. Check if the surfaces of reactor and insulator are dirty. (If necessary, clean the reactor and insulator according to stipulations in Chapter 7 of this manual)		
8. Check if the surface coating of reactor winding is damaged. If necessary, mend the damaged surface (see Chapter 7 in this manual).		
9. Before the power is connected, get rid of all items with no relation to the operation of reactor, such as tools, bolts, metal parts, ladder and felt.		
10. Check all equipment, fence, building and inlet cable on the surface of winding or near the winding to make sure their metal sheaths have proper yoke distances.		

Remarks: The provider may check the record in the log sheet when necessary.

Appendix II

7.3 Routine inspection or maintenance items: (1 year or 5 years interval) Signature _____ Date _____

1. Normally, carry out visual inspection on the product to see if it is complete.		
2. Check if the wire between the reactor's winding encapsulation and aluminium alloy post is damaged or broken.		
3. Check if the GRP belt on the aluminium alloy post is loosened.		
4. Check if there is any abnormality on top end and bottom end of the winding, such as carbonization and trace of electric arc.		
5. Check the top end of winding and airway to see if there is any foreign object, especially bird net. If so, eliminate the sundries.		
6. Check both the inner surface and outer surface of the reactor winding to see if there is any trace of electric discharge.		
7. Check if the bolt of the supporting structure has been tightened.		
8. Check the status of the grounding cable, such as tightening status of bolt, any sign of corrosion and etc.		
9. Check if the surfaces of the reactor and insulator are contaminated. If necessary, clean the reactor and insulator referring to stipulations in Chapter 7.		
10. Check the protective paint of the reactor. For local deficiency or peeling off of paint, repair the paint (see Chapter 7). Under normal environment conditions, it is suggested the reactor should be repainted after running for 10 to 15 years.		
11. Remove all irrelevant parts before the power is connected, such as tools, bolt, other metal parts, ladder, oil cloth and etc.		
12. If the acoustic shield is provided along with the winding, check if the sound absorption sponge within the shield is loosened or has slid away from its initial installed position.		

Remarks: The provider may check the record in the log sheet when necessary.

ROGER ALBERTON, B.A. SC., P.ENG.
VICE PRESIDENT, INTERNATIONAL SALES
MOBILE: +1 (416) 624-7853
EMAIL: Roger.alberton@Teee-inductors.com
49 Treegrove Circle
Aurora, Ontario, Canada, L4G 6M2

CALEB KRUSE
BUSINESS DEVELOPMENT MANAGER
TEL: +1 (847) 532-0193
23 S. Grove Ave
Elgin, IL 60120